

RAISSING  
ARODUCTS  
RAISSING  
ARODUCTS  
RAISSING  
ARODUCTS  
RAISSING  
ARODUCTS

Virtual  
Conversation  
Series

Program  
supported by

**TERRA**  
FOUNDATION FOR AMERICAN ART

Design  
Museum  
of Chicago

blkHaUS

## **Raising Products: Virtual Conversation Series**

**Raising Products is a virtual series on art, design, and communities of color — an ongoing discussion between scholars, artists, and designers. It is about making and unmaking. This program is supported by the Terra Foundation for American Art.**

**The project will expose the design process and its relation to fabrication, branding, and artisanship, as well as spark conversation about the history of Chicago art and design and its relevance to communities of color.**

**The series will begin with discussions between Zoë Ryan and Katherine Darnstadt, Erin Harkey and Yohance Lacour, and Paola Aguirre and Obi Nwazota. Each pair will have a 20–30 minute conversation exposing the design process and its relation to fabrication, branding, and artisanship, focusing on its relevance to communities of color and the history of art and design. Like a game of Telephone, each discussion will end with a prompt to begin the next discussion.**

## Conversation Schedule

Thursday, April 16, 6 pm

Katherine Darnstadt: Founder of Latent Design

Zoë Ryan: John H. Bryan Chair and Curator of Architecture and Design, Art Institute of Chicago

WATCH: [youtube.com](https://www.youtube.com)

---

Thursday, April 23, 6 pm

Erin Harkey: Deputy Commissioner, Programming, Department of Cultural Affairs and Special Events of the City of Chicago

Yohance Lacour: Entrepreneur, artist and activist

WATCH: [youtube.com](https://www.youtube.com)

---

Thursday, April 30, 6 pm

Paola Aguirre: Founder/Principle at Borderless Studio

Obi Nwazota: Entrepreneur and owner of Orange Skin

WATCH: [youtube.com](https://www.youtube.com)

Join us live on Zoom at 6pm or watch later on Facebook or Youtube!

## Norman Teague, **moderator**

Norman Teague, moderator, holds an MFA in Designed Objects from the School of the Art Institute of Chicago (SAIC) and a BFA in Industrial Design from Columbia College Chicago. He was awarded the Claire Rosen and Samuel Edes Foundation Prize for Emerging Artists in 2015 and is a creative collaborator in association with the exhibition design team of Ralph Applebaum & Associates (NY) and Chicago-based civic projects for the Obama Presidential Center scheduled to open in 2022.

## Katherine Darnstadt, **April 16**

Katherine Darnstadt is the founder of Latent Design, a progressive architecture and urbanism firm leveraging civic innovation and social impact to design more equitable spaces and systems. Since founding her practice in 2010, Katherine and her firm have prototyped new urban design systems to advance urban agriculture, support small business, created spaces for youth makers, advanced building innovation, and created public space frameworks. She and the firm have been published, exhibited and featured widely, most notably at the International Venice Architecture Biennial, Architizer A+ Awards, Chicago Ideas Week, NPR, American Institute of Architects Young Architects Honor Award winner and Crain's Chicago 40 Under 40. She currently teaches at The School of the Art Institute of Chicago and previously at Northwestern University.

## Zoë Ryan, **April 16**

Zoë Ryan is the John H. Bryan Chair and Curator of Architecture and Design at the Art Institute of Chicago. A curator and author, her projects focus on exploring the impact of architecture and design on society. Her recent exhibitions include, In a Cloud, in a Wall, in a Chair: Six Modernists in Mexico at Midcentury (2019) and Past Forward: Architecture and Design at the Art Institute, a major installation of the modern and contemporary architecture and design collections (2017–ongoing). In 2017, she published As Seen: Exhibitions that Made Architecture and Design History, the first volume to explore in depth the important role that exhibitions have played in the history of these fields of practice.

## Erin Harkey, April 23

Erin Harkey is the Deputy Commissioner, Programming, Department of Cultural Affairs and Special Events of the City of Chicago. Prior to joining the Los Angeles County Arts Commission, Ms. Harkey served as the Associate Director of Public Art & Design at the Arts Council for Long Beach where she managed temporary and permanent public art projects. Ms. Harkey has also worked for the District of Columbia Arts Center, Washington, DC; the Japanese American National Museum, Los Angeles, CA; the Music Center of Los Angeles County; and the Los Angeles Community Redevelopment Agency, Cultural Planning Bureau. Ms. Harkey holds two Master's degrees from the University of Southern California in Urban Planning and Public Art Studies.

## Yohance Lacour, April 23

The YJL Sneaker collection is an intersection of luxury, fine art and fortitude. As a kid growing up on the Southside of Chicago, a 'sneakerhead' long before the phrase was ever coined, I was a part of a subculture that would reshape the American landscape forever. Hip-hop was in its infancy and my friends and I were both raising it, and being raised by it. The rest of the country guaranteed it would die out, but we were forging a global phenomenon. We not only created industries, we cemented our place as the world's official trendsetter and most prominent cultural influencer.

## Paola Aguirre, April 30

Paola Aguirre is the founder of Borderless, urban design and research practice based in Chicago. Paola has been trained as an architect and urban designer, and her professional experience includes working with government, universities and architecture/urban design offices both in Mexico and the United States. Paola currently teaches at The School of the Art Institute of Chicago, and has taught at Washington University in St. Louis and Archeworks. She also enjoys documenting and writing about urban research, explorations and experiences, and has contributed with pieces to Next City, Scapegoat Journal, MAS Context, and Arquine.

## Obi Nwazota, April 30

Obi Nwazota is a cultural entrepreneur who trained as an architect at the University of Illinois; he owns Orange Skin, an interior design and display firm in River North. OrangeSkin is a leading source for modern and contemporary furniture in Chicago. Design consultation offered. Curated collection of top brands on display.

---

## Support Chicago's Artists & Designers

**Arts Leaders of Color Emergency Fund**  
Looking for ways to make immediate impact in communities discussed tonight? The Arts Leaders of Color Emergency Fund is directly supporting BIPOC (Black, Indigenous, People of Color) artists AND administrators (consultants, facilitators, box office staff, seasonal/temporary employees, etc.) who have been financially impacted due to COVID-19. Learn more here: [gofundme.com](https://gofundme.com)

**For the People Artists Collective**  
On a local level, For the People Collective is working to offer emergency microgrants of up to \$500 to Illinois-based artists and freelancers of color whose income has been affected during the COVID-19 pandemic. This fund is available as funds become available. For the most up-to-date information about applying or donating, please visit [forthepeoplecollective.org](https://forthepeoplecollective.org)

## blkHaUS

blkHaUS studios is a Chicago based, socially-focused design studio dedicated to using design as an agent of change to uplift and transform marginal communities. They strive for our work and presence in the design profession to instigate greater inclusion of black and brown narratives in the history of design and promote design's relevance to contemporary communities of color. blkHaUS feels design is a language that can be used as an agent of change. As makers and educators, they aim to develop educational pedagogies and creative methodologies, so that communities of color can thrive and be seated at the tables of power influencing contemporary urban and social design. [blkhausstudios.com](http://blkhausstudios.com)

## Design Museum of Chicago

The Design Museum of Chicago educates, inspires, and fosters innovation through design. They believe design has the fundamental capacity to improve the human condition, and strive to make it accessible to everyone through free exhibitions. The museum strives to meet people where they are, facilitating conversations around design with a variety of voices, backgrounds, and viewpoints. They believe that design is not just a single discipline or process, but rather a persistent element present in our everyday environments and experiences. [designchicago.org](http://designchicago.org)

Thank you  
to Stony Island  
Arts Bank!

## Stony Island Arts Bank

A special thank you to Stony Island Arts Bank, the original venue for this series. [rebuild-foundation.org](http://rebuild-foundation.org)

## TERRA

FOUNDATION FOR AMERICAN ART

Raising Products is possible due to support from the Terra Foundation for American Art. The Terra Foundation for American Art is dedicated to fostering exploration, understanding, and enjoyment of the visual arts of the United States for national and international audiences. Recognizing the importance of experiencing original works of art, the foundation provides opportunities for interaction and study, beginning with the presentation and growth of its own art collection in Chicago. To further cross-cultural dialogue on American art, the foundation supports and collaborates on innovative exhibitions, research, and educational programs. Implicit in such activities is the belief that art has the potential both to distinguish cultures and to unite them. [terraamericanart.org](http://terraamericanart.org)



# **Inspirational Artists and Designers**

J. E. MATZELIGER.

LASTING MACHINE.

No. 274,207.

Patented Mar. 20, 1883.

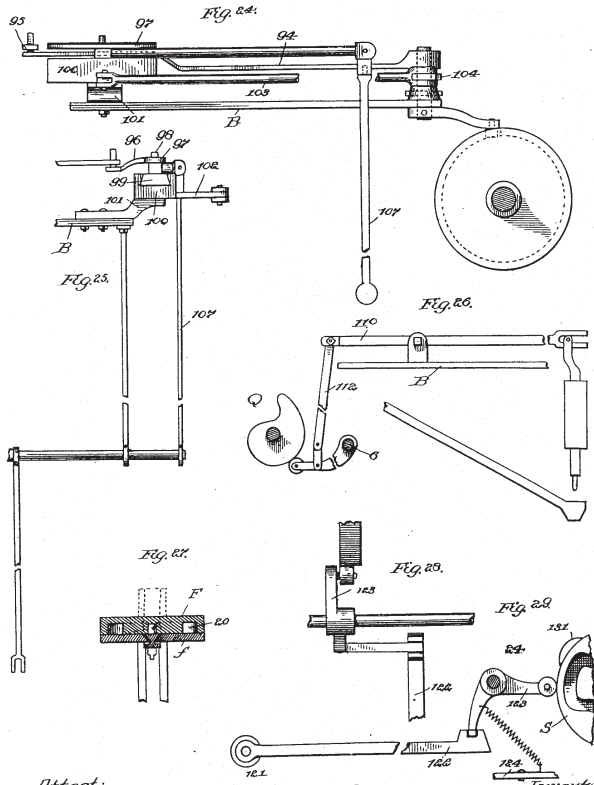

Attest:  
*Walter Waldron*  
*W. Jay*

*Jan E. Matzelliger*  
 Inventor  
*Ellis Spear*  
 Atty

N. PETERSON PHOTOGRAPHIC WASHINGTON, D. C.

### Jan Ernst Matzelliger

Automatic shoe laster – increased shoe production by at least 300%.

E. MCCOY.

Improvement in Lubricators for Steam-Engines.

No. 129,843.

Patented July 23, 1872.

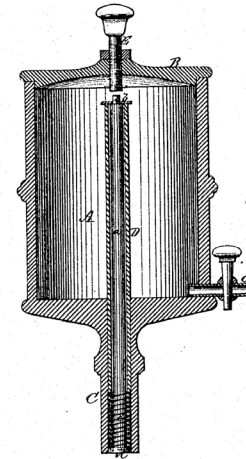

Witnesses  
*John A. Ellis*  
*C. H. Watson*

Inventor  
*Elijah McCoy*  
 Atty  
*W. Alexander*

A.M. PHOTO-LITHOGRAPHIC CO. (U.S. PATENT PROCESS)

### Elijah McCoy

Patent for Steam Engine Lubricator, which significantly increased efficiency of trains and led to the phrase, "The Real McCoy."



## Paul Revere Williams

La Concha Motel, Las Vegas, NV. Now the lobby building of the Neon Museum.

By Carol M. Highsmith - <https://www.loc.gov/resource/highsm.13673/>, Public Domain, <https://commons.wikimedia.org/w/index.php?curid=64098605>.



## David Adjaye

Smithsonian National Museum of African American History and Culture.

By Frank Schulenburg - Own work, CC BY-SA 4.0, <https://commons.wikimedia.org/w/index.php?curid=87514400>.





## Philip Freelon

National Center for Civil and Human Rights.  
By Marco Correa - Own work, CC BY-SA 4.0, <https://commons.wikimedia.org/w/index.php?curid=39679910>.



## Charles Harrison

Redesigned ViewMaster.  
Image: Cooper Hewitt.

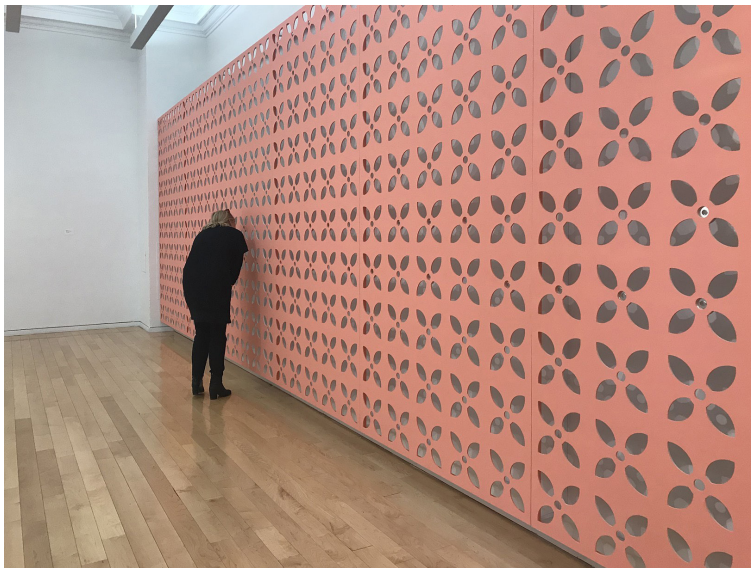

## Edra Soto

Graft, installed at Chicago Cultural Center.  
Image from Edra Soto.

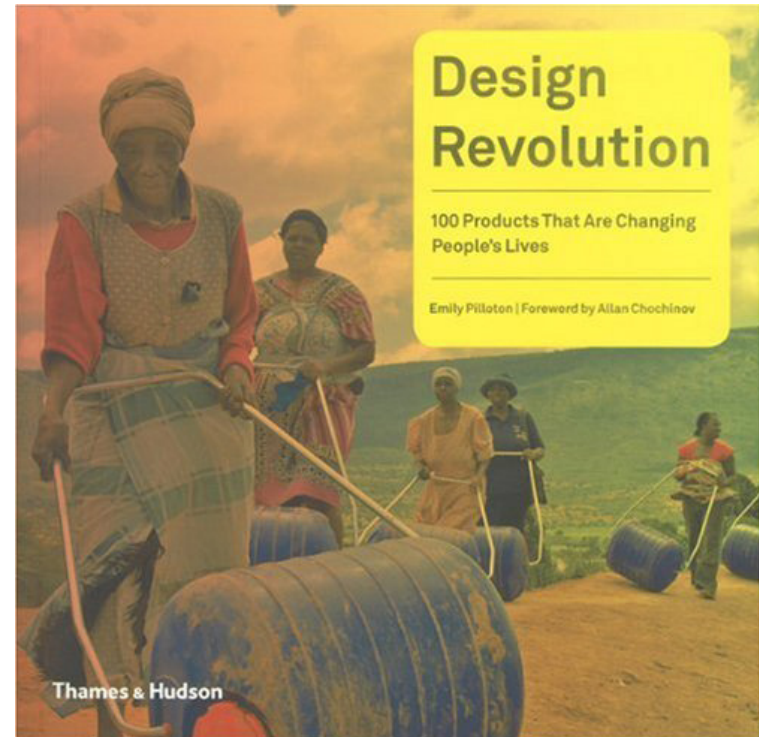

## Emily Pilloton

Author of Design Revolution: 100 Products That are Changing  
People's Lives



## Gladys Theus

History of women in the trades: "Miss Gladys Theus, one of the fastest and most efficient welders at the Kaiser Company Permanente Metals Corporation yards near Oakland, Calif., is sticking to her job until final victory is won." National Archives and Records Administration.



## Gordon Parks

"Self-portrait." Reportedly, this portrait was made in the South Side Community Art Center studio. Vivian G. Harsh Research Collection of Afro-American History and Literature, Chicago Public Library. Horace Cayton Papers. Rights: Gordon Parks Foundation.

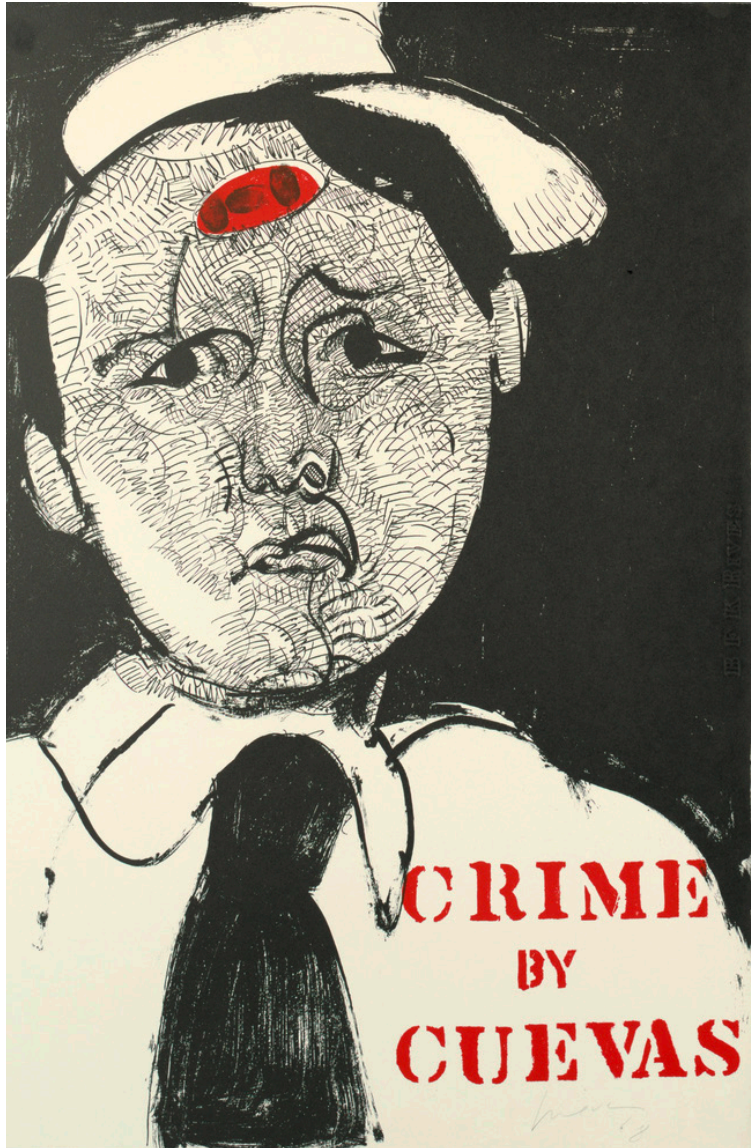

**José Luis Cuevas**

Poster, *Crime by Cuevas*; Designed by José Luis Cuevas (Mexican, b. 1934); USA; Gift of the Museum of Graphic Art, New York; 1973-39-417.  
From the Cooper Hewitt collection. Accession Number 1973-39-417, Object ID 18481223



**Eric J. Garcia**

*Viva Joaquin.*  
Rights: Eric J. Garcia.



## Henry Tanner

Gateway, Tangier.  
St. Louis Art Museum, 33:2005



## Guadalupe Maravilla

"Disease Thrower #5." Featuring a star-patterned woven structure made from a Mexican medicinal plant. Places the cancer upon the shrine via anatomical models.  
Rights: Jack Barrett Gallery, New York



## Charles Sebree

Harlem Saltimbanques.  
From the Smithsonian American Art Museum  
Gift of International Business Machines Corporation, 1969.127



## Pablo O'Higgins

Print, The Market; Pablo O'Higgins (American, 1904–1983);  
Mexico; lithograph in colored inks on white paper; 1953-102-103  
From the Cooper Hewitt collection. Accession Number 1953-  
102-103 Object ID 18393709



### Baruj Salinas

Non-representational abstraction style.  
Image from MLA Gallery, Los Angeles.



### Lidya Buzio

Untitled Roofscape Vessel.  
Smithsonian American Art Museum, Museum purchase through the  
Renwick Acquisitions Fund, 1995.65, © 1986, Lydia Buzio



## David Driskell

Oil and collage on canvas.  
DC Moore Gallery



## Luis Cruz Azaceta

The Plague, AIDS Epidemic.  
By Luis Cruz Azaceta - Own work, CC BY-SA 3.0



# Design Museum of Chicago

Inspiring, educating, and  
innovating through design.

[info@designchicago.org](mailto:info@designchicago.org)

312 894 6263

[@designmuseumchi](#)

Support the Design Museum by  
joining our Patreon [patreon.com](https://www.patreon.com/designmuseum)

or making a one-time donation

[designmuseum.org/support](https://designmuseum.org/support)